

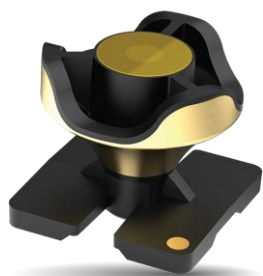

Part No. 9002305L0-L01K

UWB LDS Antenna ("Tulip")

6.0 – 8.5 GHz



KYOCERA AVXs' 9002305L0-L01K is an innovative - one of its kind on-board UWB antenna optimized for applications spanning 6.0 – 8.5 GHz. This antenna is manufactured using Laser Direct Structuring (LDS) technology. The LDS technology is a revolutionary approach offering a streamlined and efficient process for creating complex 3D circuits on a myriad of substrates. LDS technology is ideal when more curves are needed or less 3D volume is available.

This innovative antenna is characterized by its phase stability that remains the same in all directions around the antenna.

UWB LDS Antenna ("Tulip")

6000 – 8500 MHz

KEY BENEFITS

Stay-in-Tune

KYOCERA AVXs antenna technology provides superior RF field containment, resulting in less interaction with surrounding components.

Quicker Time-to-Market

By optimizing antenna size, performance and emissions, customer and regulatory specifications are more easily met.

Environmental Compliance

Products are the latest RoHS and REACH version compliant

APPLICATIONS

- Anchors
- Handheld
- Telematics
- Tracking
- Healthcare (FDA Class I)
- M2M Industrial devices
- Smart city
- Smart mobility
- Fitness
- Smart Retail
- Connectivity
- Security

Electrical Specifications

Typical Performance on 40 x 40 mm PCB

Frequency	6.0 – 8.5 GHz
Peak Gain	4.3 dBi
Average Efficiency	61%
VSWR Match	< 5.0 :1 max
Max Group Delay	2 ns
Feed Point Impedance	50 ohms unbalanced
Polarization	Linear
Power Handling	2 Watt CW

Mechanical Specifications & Ordering Part Number

Ordering Part #	9002305L0-L01K
Dimensions (mm)	6.40 x 6.40 x 5.52
Weight (grams)	< 0.1
Mounting	SMT (Pick-and-Place)
Demo Board	9002305L0-L01-04
Storage Temperature (°C) / Humidity	-40 to +85 / 45~75% (Sealed Shipping Pack)
Operation Temperature (°C)	-40 to +85
Packaging	Tape & Reel
Variant	9002305L0-L01 (without Polyimide Adhesive)

KYOCERA AVX UWB LDS Antenna (“Tulip”) Specifications.
 KYOCERA AVX produces a wide variety of standard and custom antennas to meet user needs.

Environmental Specifications Summary

High Temperature and High Humidity (HTHH) Test	Conditions: Temperature: +85°C, Humidity: 85% RH, Test Duration: 96 Hours Acceptance Criteria: No visible Corrosion.
Salt Spray Test	Conditions: Expose to a +35 ±3 °C spray of a 5% (by volume) resolution of NaCl in water for 48 hours. Acceptance Criteria: No visible Corrosion / Discoloration acceptable.

Antenna 3D View: 9002305L0-L01

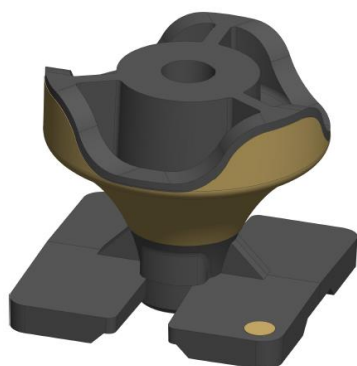

Top View

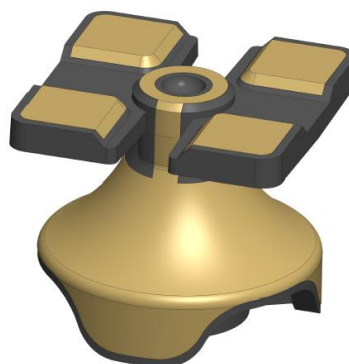

Bottom View

Antenna 3D View: 9002305L0-L01K

Same version as 9002305L0-L01 but with additional Polyimide Adhesive

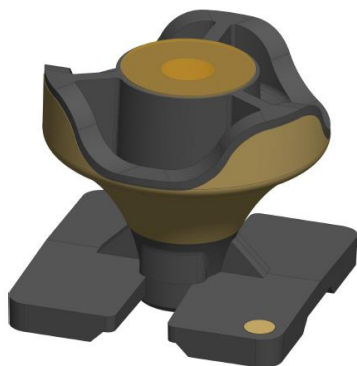

Top View

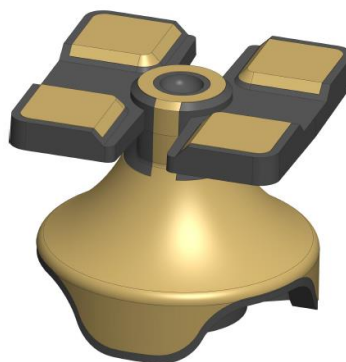

Bottom View

KYOCERA AVX UWB LDS Antenna (“Tulip”) Specifications.
 KYOCERA AVX produces a wide variety of standard and custom antennas to meet user needs.

Antenna Dimensions

Typical antenna dimensions (mm)

Part Number	A (mm)	B (mm)	C (mm)
9002305L0-L01	6.40	6.40	5.52
9002305L0-L0K	6.40	6.40	5.58

9002305L0-L01:

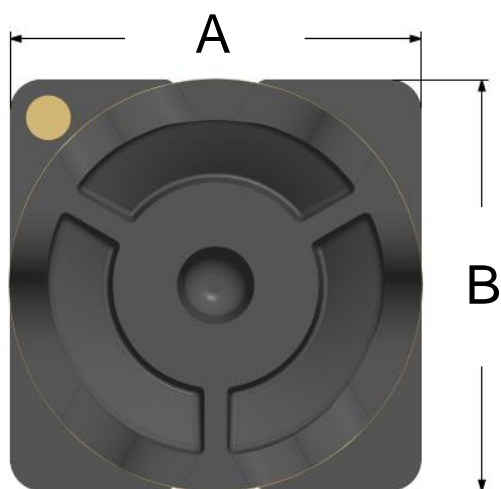

9002305L0-L01K:

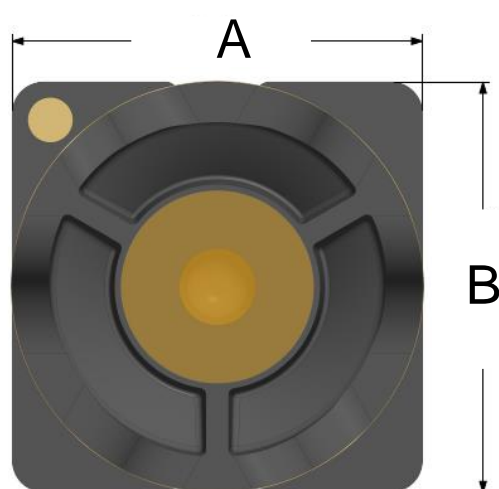

KYOCERA AVX UWB LDS Antenna (“Tulip”) Specifications.
 KYOCERA AVXs produces a wide variety of standard and custom antennas to meet user needs.

Return Loss, Efficiency and Peak Gain plots

Typical Performance on 40 x 40 mm PCB

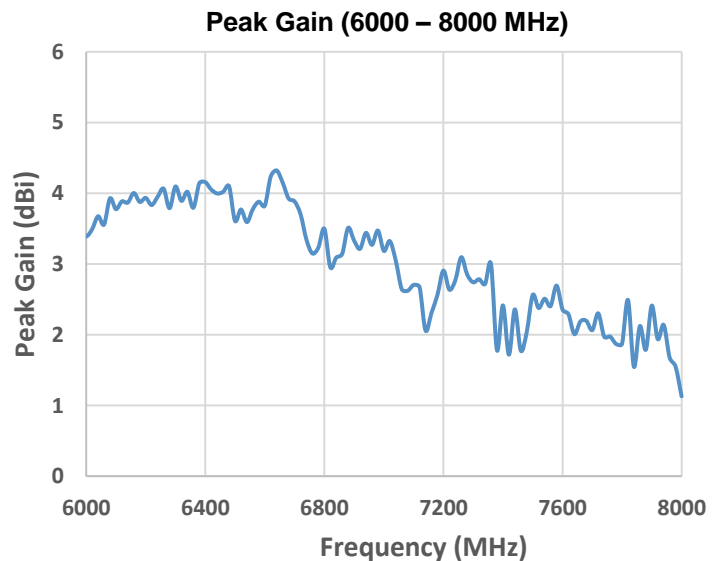
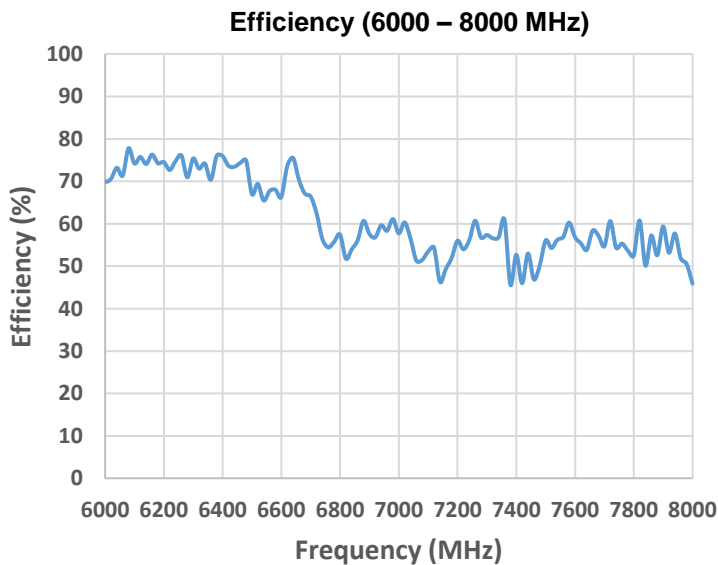
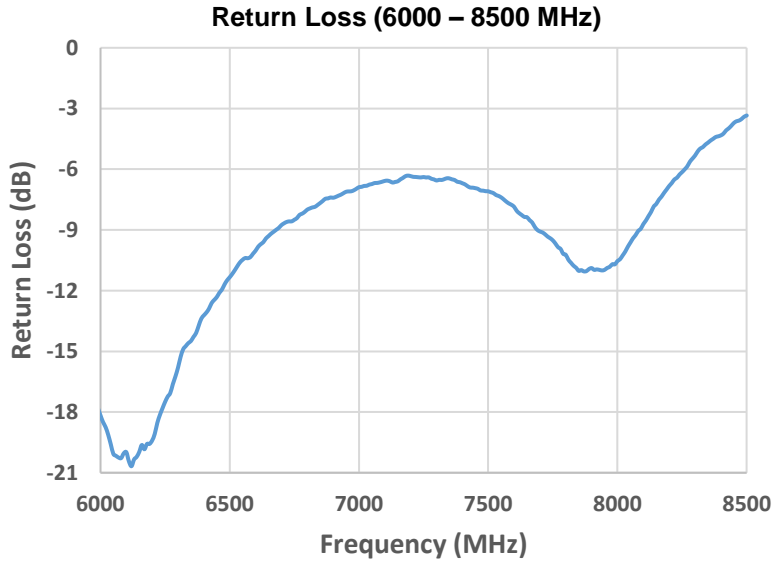

KYOCERA AVX UWB LDS Antenna (“Tulip”) Specifications.
 KYOCERA AVXs produces a wide variety of standard and custom antennas to meet user needs.

Group Delay plots

Typical Performance on 40 x 40 mm PCB

Channel 5:

Channel 9:

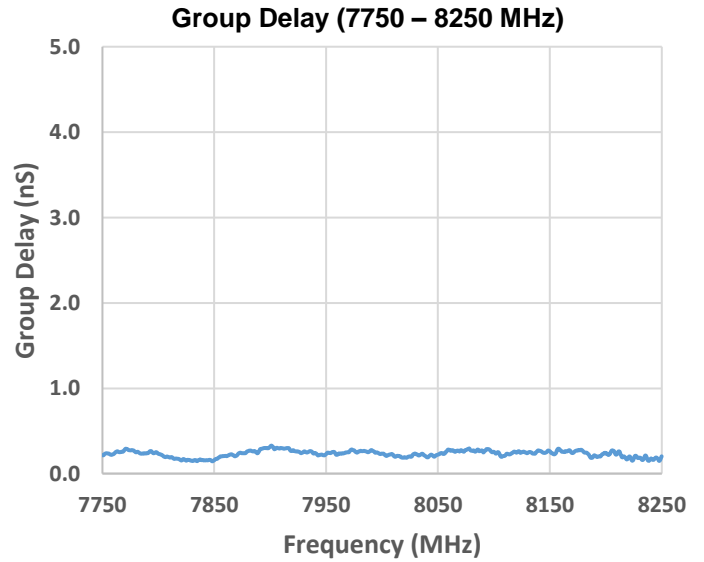
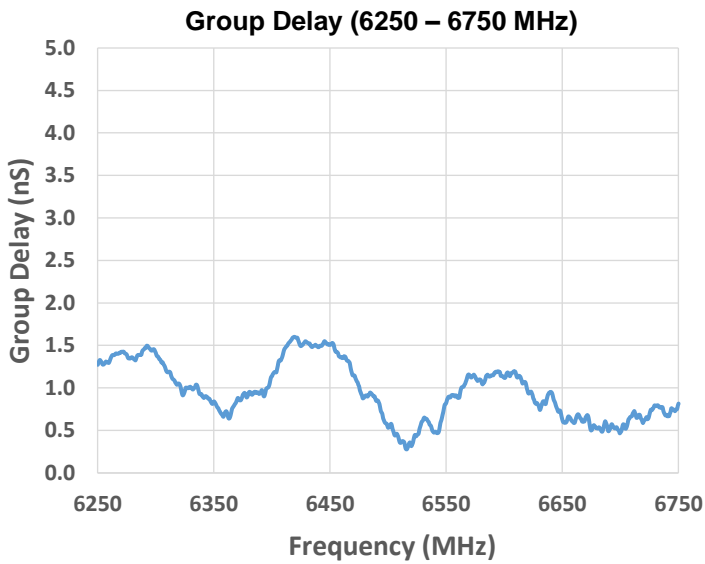

KYOCERA AVX UWB LDS Antenna (“Tulip”) Specifications.
 KYOCERA AVXs produces a wide variety of standard and custom antennas to meet user needs.

Radiation Patterns Plots

Typical Performance on 40 x 40 mm PCB

Typical Performance @ 6000, 6500, 7000, 7500, 8000 MHz

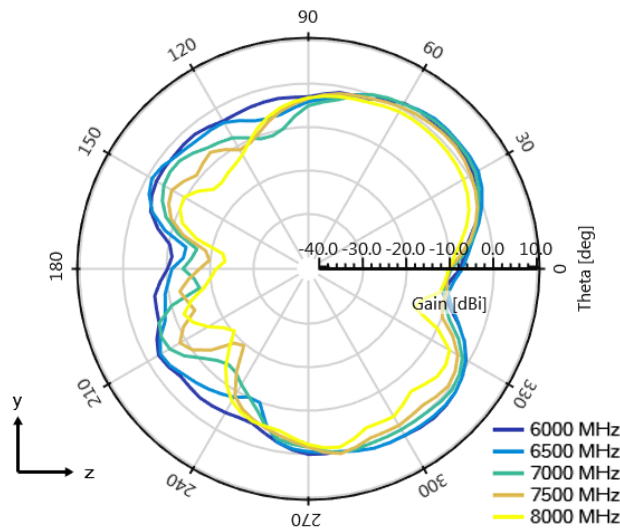
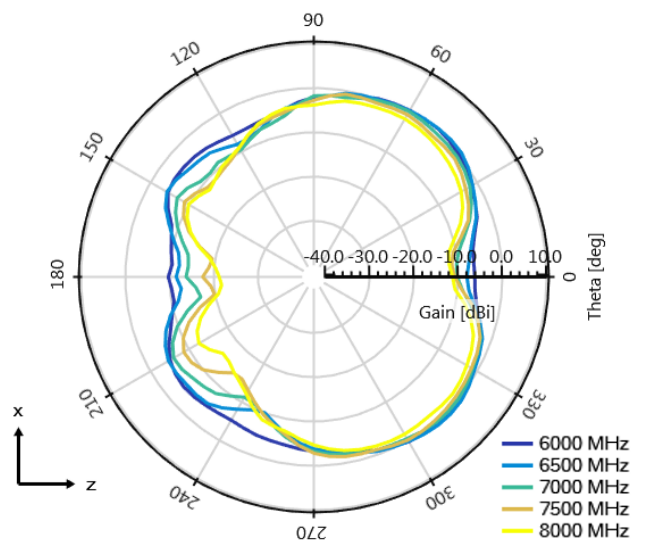
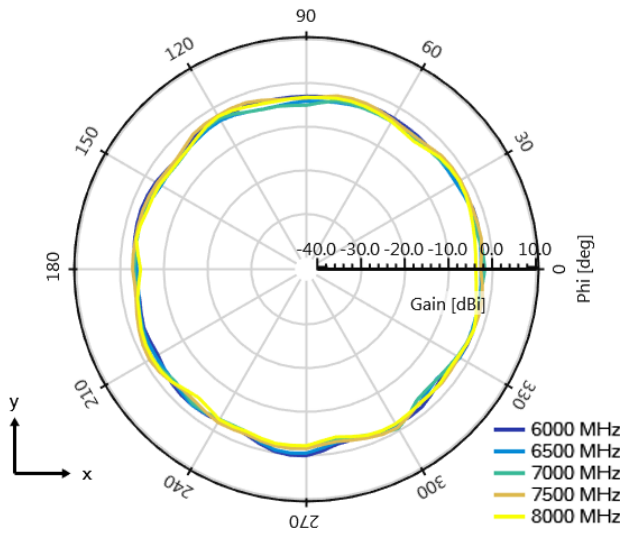
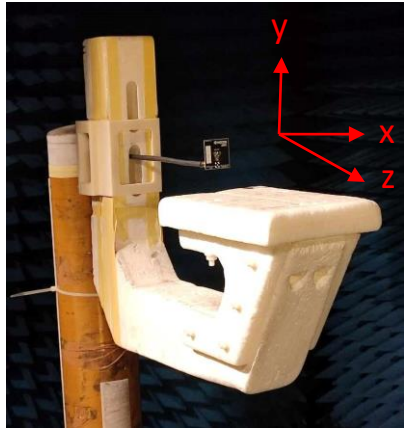

KYOCERA AVX UWB LDS Antenna (“Tulip”) Specifications.
 KYOCERA AVX produces a wide variety of standard and custom antennas to meet user needs.

Antenna layout (9002305L0-L01-04)

Typical layout dimensions (mm)

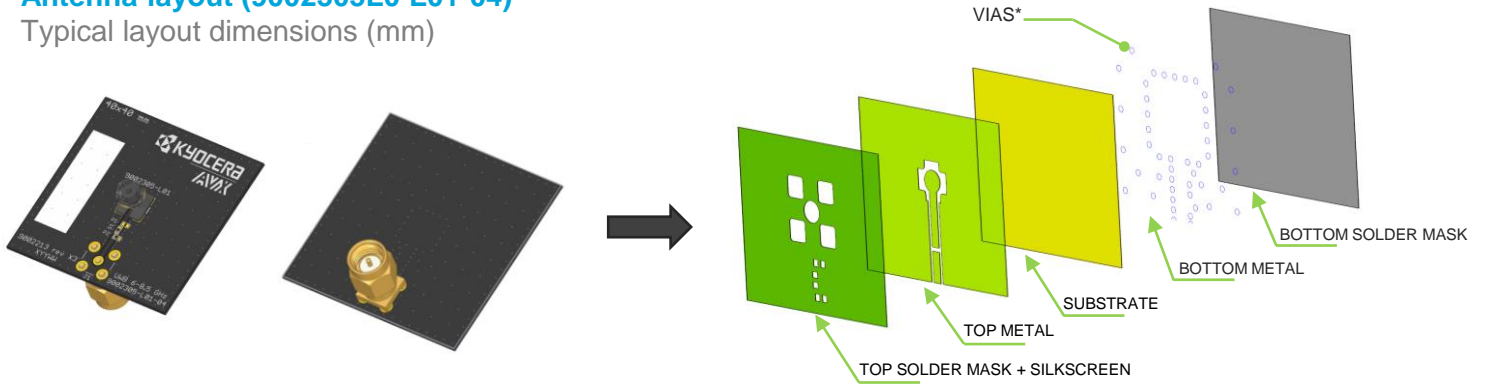

- Additional VIAS: Diam. 0.20 mm to be placed around antenna, (no vias on transmission lines).
- Via holes must be covered by solder mask
- DXF Layout available to download on the website

Top Solder Mask:

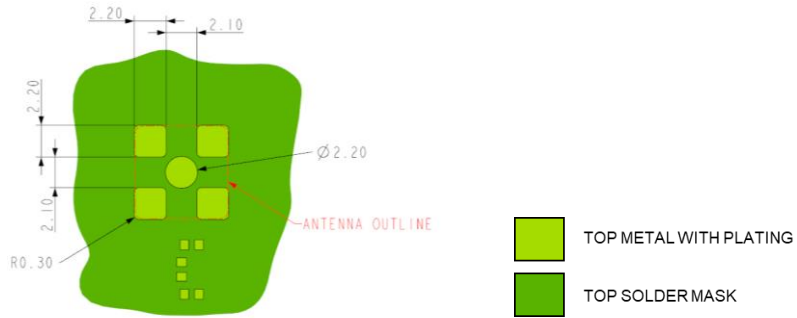

Top Metal:

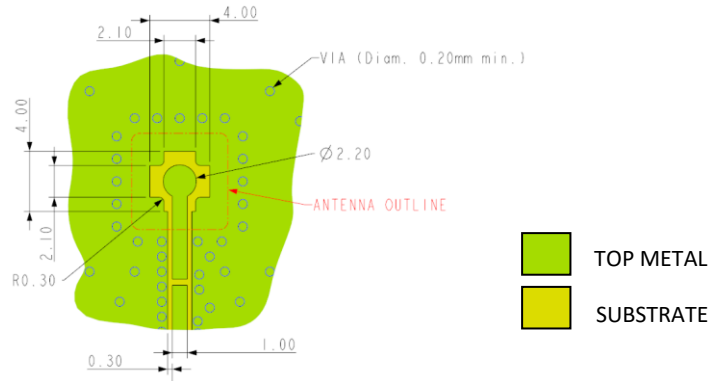

Bottom Metal:

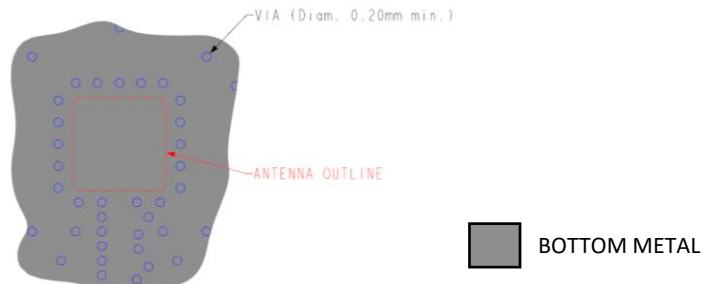

KYOCERA AVX UWB LDS Antenna (“Tulip”) Specifications.
 KYOCERA AVXs produces a wide variety of standard and custom antennas to meet user needs.

Antenna Demo Board (9002305L0-L01-04)

Typical layout dimensions (mm)

Part Number	A	B	C
9002305L0-L01-04	(40.0)	(40.0)	(0.80)

*Dimensions in () parenthesis are Reference Only.

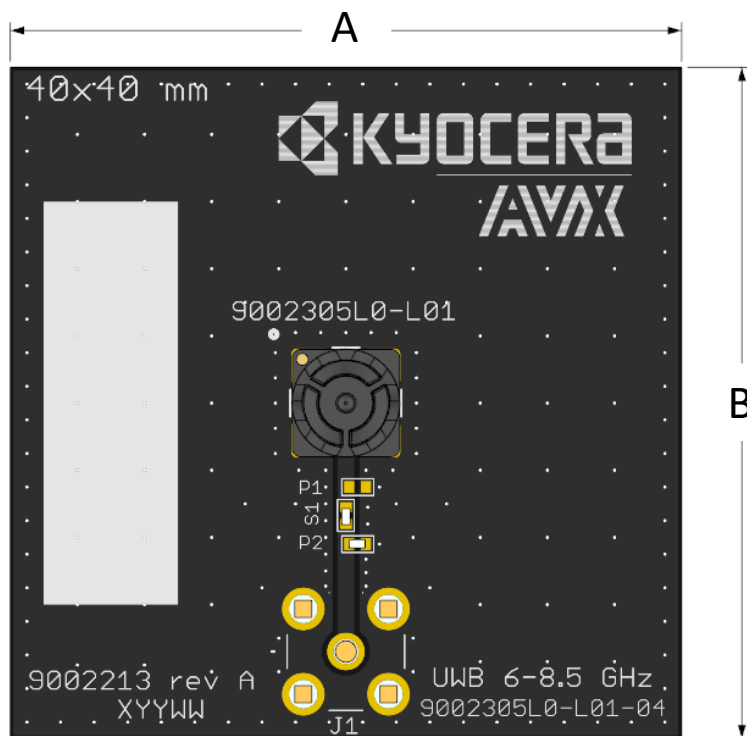

Top View

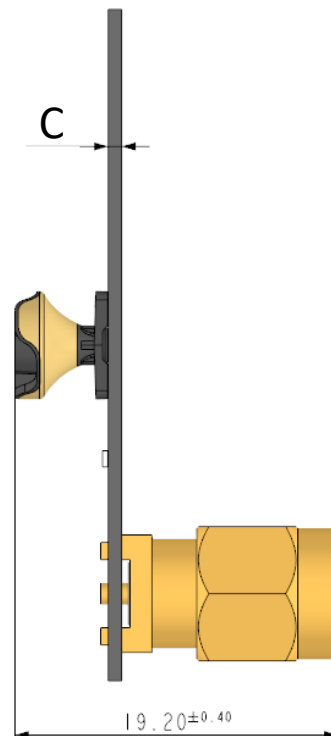

Side View

KYOCERA AVX UWB LDS Antenna (“Tulip”) Specifications.
 KYOCERA AVX produces a wide variety of standard and custom antennas to meet user needs.

Recommended Reflow Soldering Profile

The recommended method for soldering the antenna to the board is forced convection reflow soldering. The following suggestions provide information on how to optimize the reflow process for the LDS antenna:

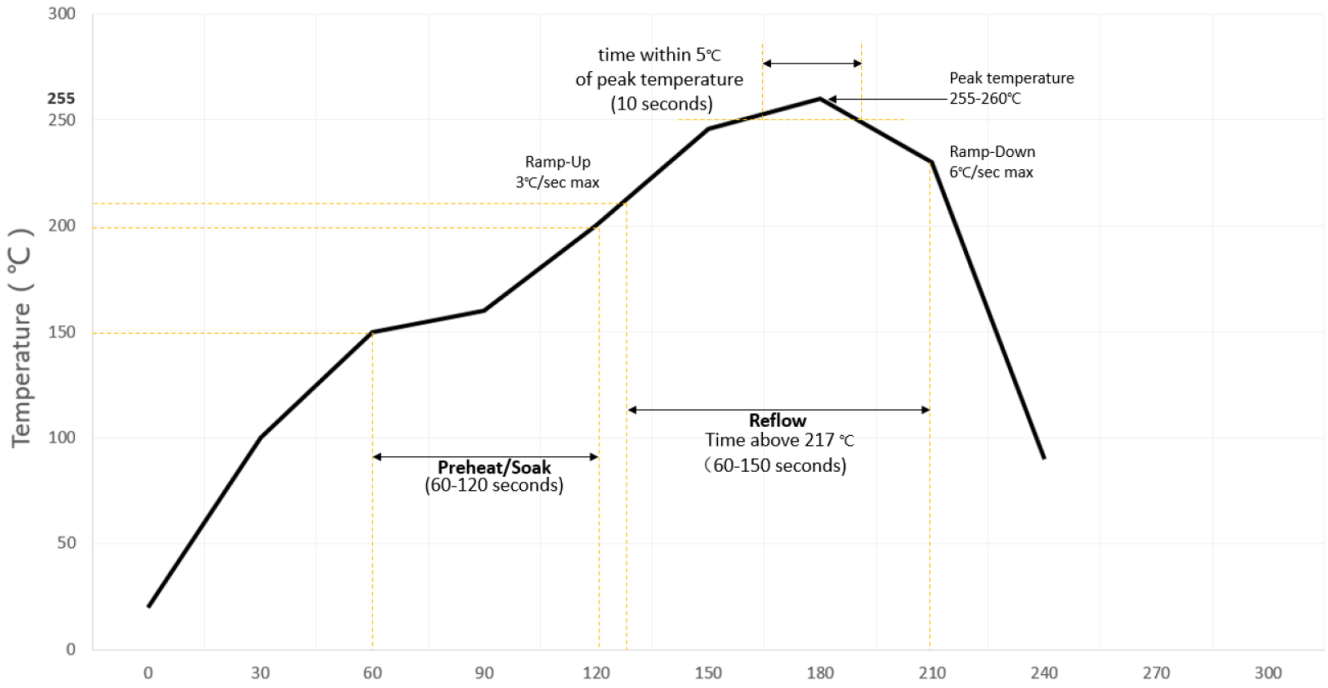

KYOCERA AVX UWB LDS Antenna (“Tulip”) Specifications.
 KYOCERA AVX produces a wide variety of standard and custom antennas to meet user needs.

Packaging

PACKAGING REQUIREMENT:

- TAPE AND REEL (EMBOSSED CARRIER TAPE), SEE BELOW SPECIFICATIONS:
- REEL SIZE $\varnothing 330 \times 18.5\text{mm}$
 - CARRIER TAPE - ALL DIMENSIONS ARE DEFINED IN ACCORDANCE WITH THE EIA-481-C STANDARD
 - MATERIAL: PET - THICKNESS: $0.40 \pm 0.05\text{mm}$ - COLOR: TRANSPARENT
 - QTY/REEL: 1000 PARTS

