

Part No. 9003379

Dual-Feed GPS L1/L5 Stacked Patch Antenna

1164 – 1189 MHz, 1563 - 1587MHz
 Supports: GPS L1, L5



KYOCERA AVX series of GPS Ceramic Patch Antennas deliver on the key needs of device designers for higher functionality and performance in IoT designs. These innovative antennas provide compelling advantages for GPS.

9003379 is a Dual-Feed ceramic stacked patch Antenna covering GPS (L1/L5) with Elliptical Polarization.

Dual-Feed GPS L1/L5 Stacked Patch Antenna

1164 – 1189 MHz
 1563 – 1587 MHz

KEY BENEFITS

Reduced Costs and Time-to-Market

Standard antenna eliminates design fees and cycle time associated with a custom solution; getting products to market faster.

Quicker Time-to-Market

By optimizing antenna size, performance and emissions, customer and regulatory specifications are more easily met.

Environmental Compliance

Products are the latest RoHS version compliant.

APPLICATIONS

- Telematics
- Tracking
- Navigation
- RTK
- Healthcare Applications (FDA Class I)
- Industrial devices
- Smart Grid
- Metering
- IoT

Electrical Specifications

Typical Characteristics antenna measured over 70 x 70 mm EVB.

Frequency (MHz)	Free Space	
	1164 – 1189 (L5)	1563 – 1587 (L1)
Peak Gain	5 dBi	5.2 dBi
Average Efficiency	58%	73%
RL Match	< - 3 dB	< - 7 dB
Gain Zenith	2 dBic @ 1180 MHz	3.9 dBic @ 1575 MHz
Axial Ratio	9.7 dBic @ 1180 MHz	5.4 dBic @ 1575 MHz
Feed Point Impedance	50 Ω unbalanced	
Polarization	Elliptical	
Radiation Pattern	Directional	

Mechanical Specifications & Ordering Part Number

Ordering Part Number	9003379
Dimensions (mm)	33.0 x 33.0 x 9.5
Mounting Type(s)	Pins + Adhesive
Weight (grams)	26.6
Operating Temperature (°C)	[-40 ~ +85°C]
Packing	Tray
Additional Resources	Download DXF and 3D Fit Files

Dual-Feed GPS L1/L5 Stacked Patch Antenna Specifications.
 KYOCERA AVX produces a wide variety of standard and custom antennas to meet user needs.

Return Loss, Efficiency and Peak Gain Plots

Typical performance 9003379 measured over 70 x 70 mm EVB

Return Loss L5 (1164 – 1189 MHz)

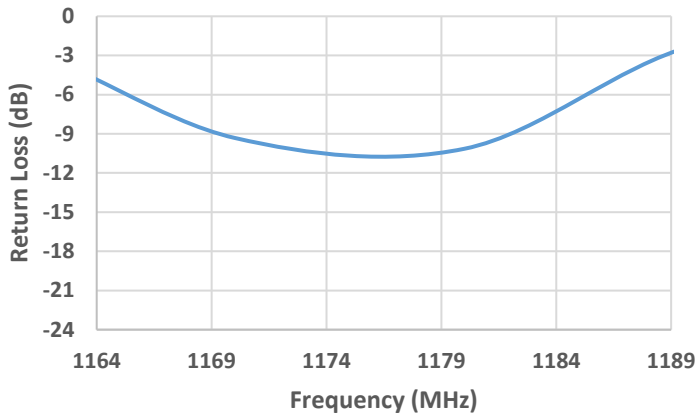

Return Loss L1 (1563 – 1587 MHz)

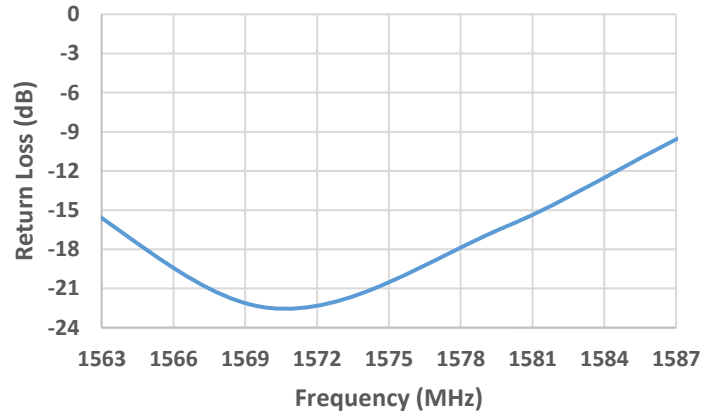

Efficiency L5 (1164 – 1189 MHz)

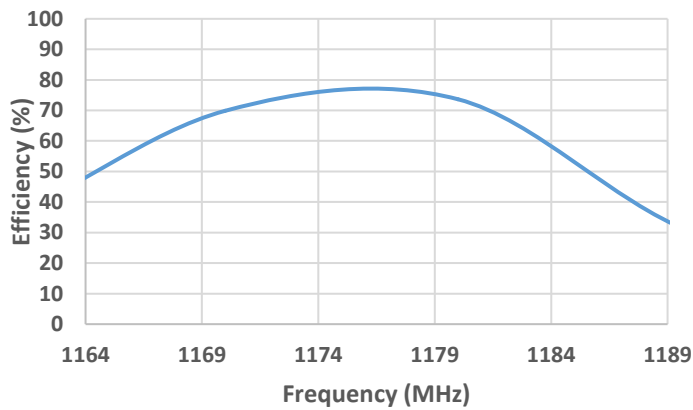

Efficiency L1 (1563 – 1587 MHz)

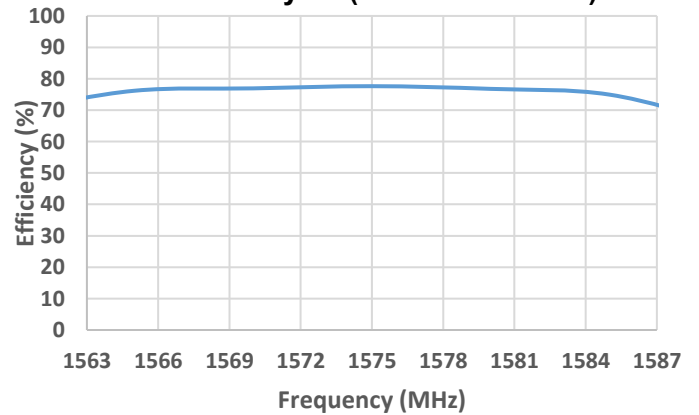

Peak Gain L5 (1164 – 1189 MHz)

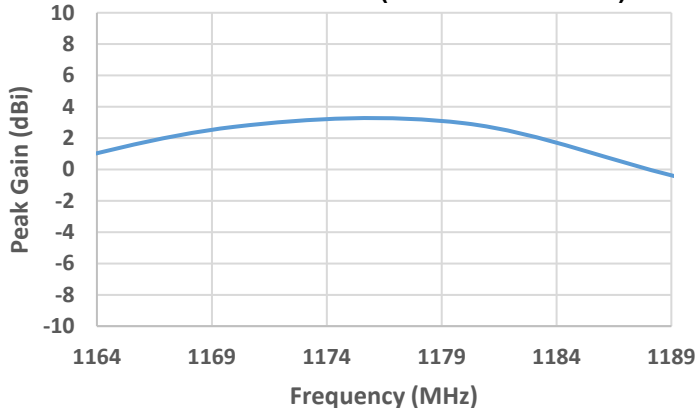

Peak Gain L1 (1563 – 1587 MHz)

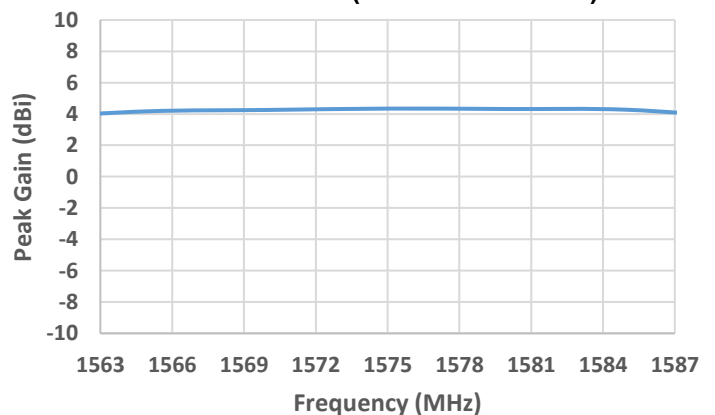

Dual-Feed GPS L1/L5 Stacked Patch Antenna Specifications.
 KYOCERA AVX produces a wide variety of standard and custom antennas to meet user needs.

Antenna Radiation Patterns

Typical performance 9003379 performance over 70 x 70 mm EVB.
 Measured @1175 MHz

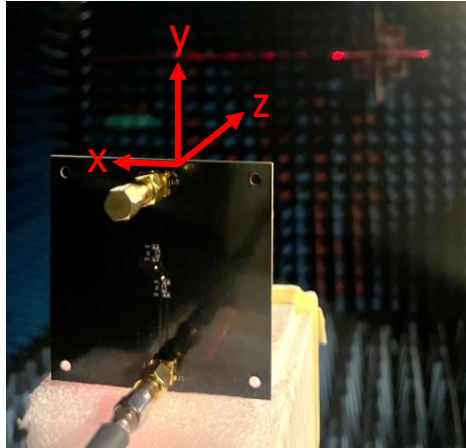

Gain (Total) - $\theta = 90$ deg - 1180 MHz [Plane XY]

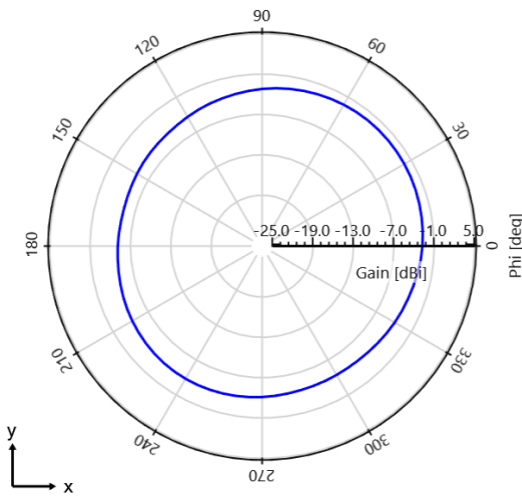

Gain (Total) - $\phi = 0$ deg - 1180 MHz [Plane XZ]

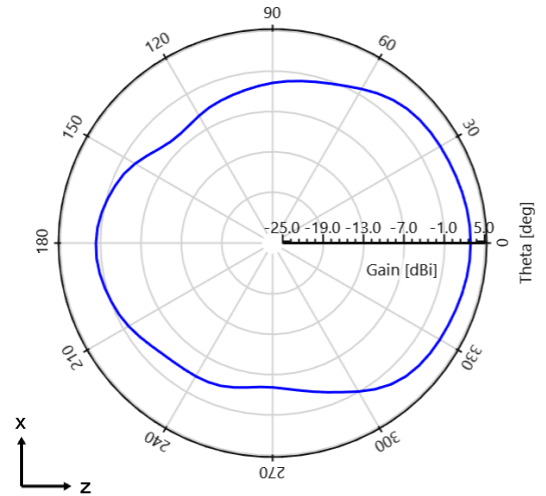

Gain (Total) - $\phi = 90$ deg - 1180 MHz [Plane YZ]

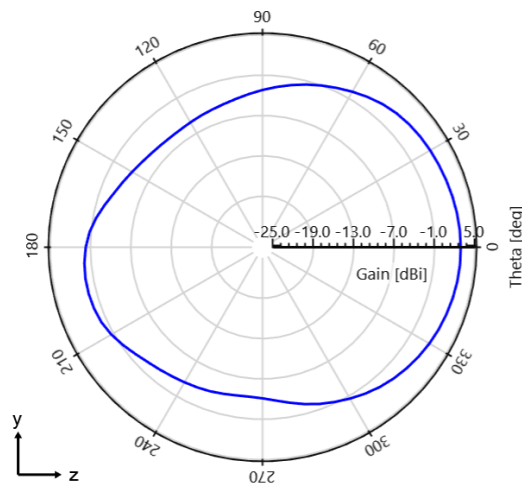

Dual-Feed GPS L1/L5 Stacked Patch Antenna Specifications.
 KYOCERA AVX produces a wide variety of standard and custom antennas to meet user needs.

Antenna Radiation Patterns

Typical performance 9003379 performance over 70 x 70 mm EVB.
 Measured @1575 MHz

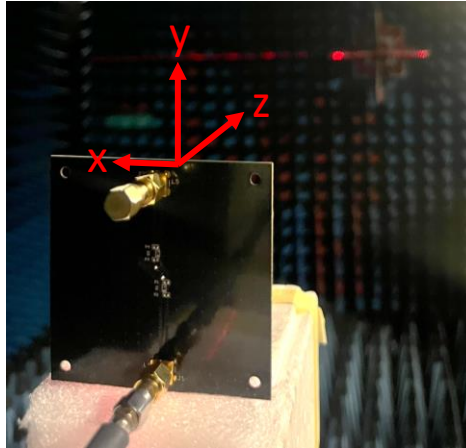

Gain (Total) - $\theta = 90$ deg - 1575 MHz [Plane XY]

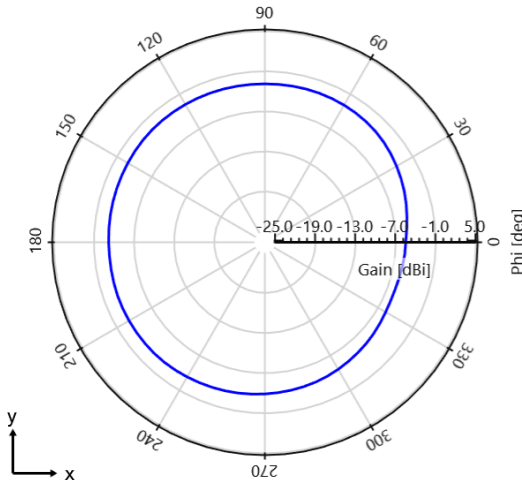

Gain (Total) - $\phi = 0$ deg - 1575 MHz [Plane XZ]

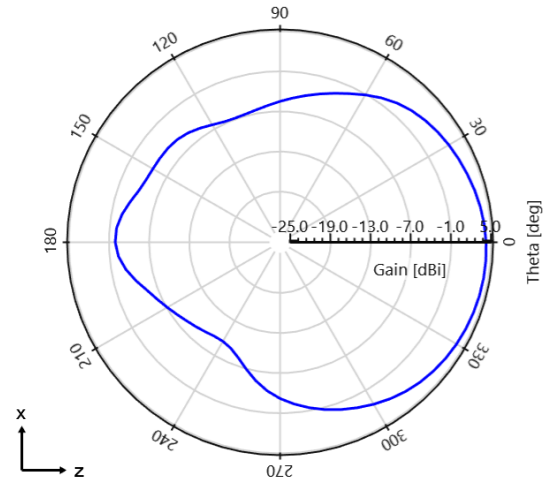

Gain (Total) - $\phi = 90$ deg - 1575 MHz [Plane YZ]

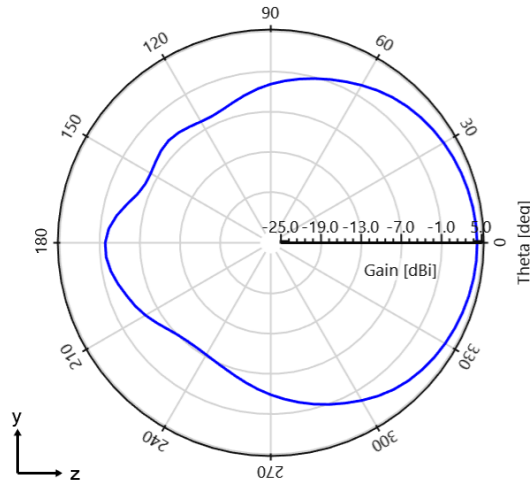

Dual-Feed GPS L1/L5 Stacked Patch Antenna Specifications.
 KYOCERA AVX produces a wide variety of standard and custom antennas to meet user needs.

R.H.C.P Gain and Axial Ratio Data

Typical performance 9003379 measured over 70 x 70 mm EVB @1175 MHz

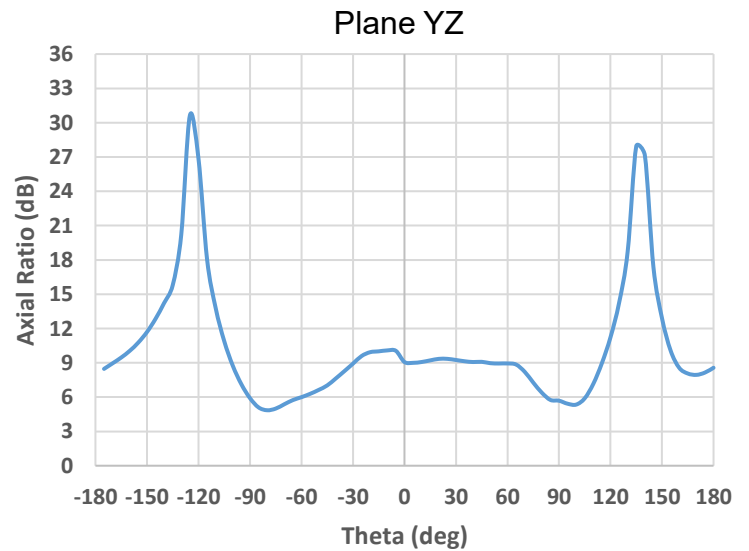
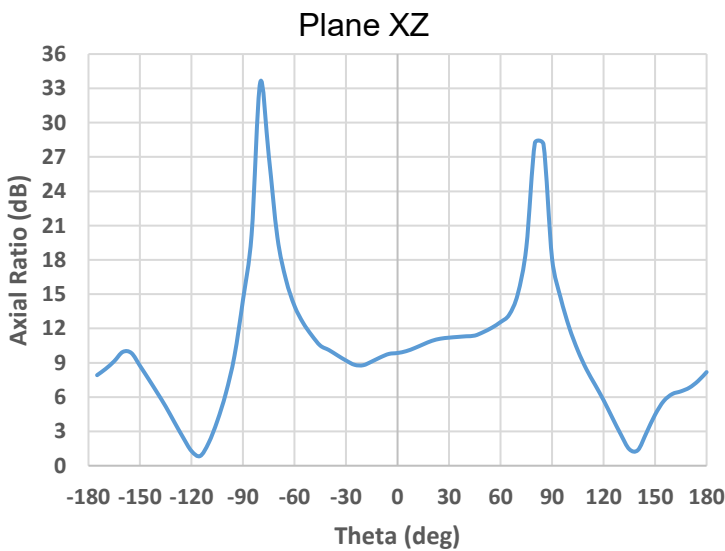
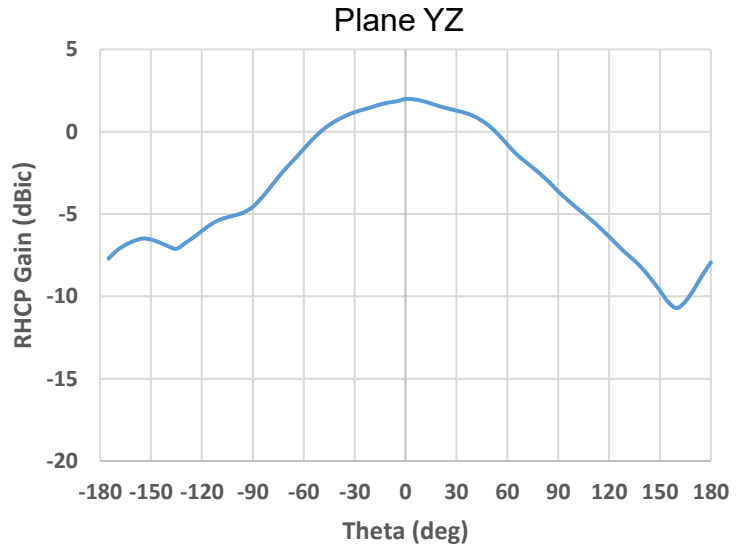
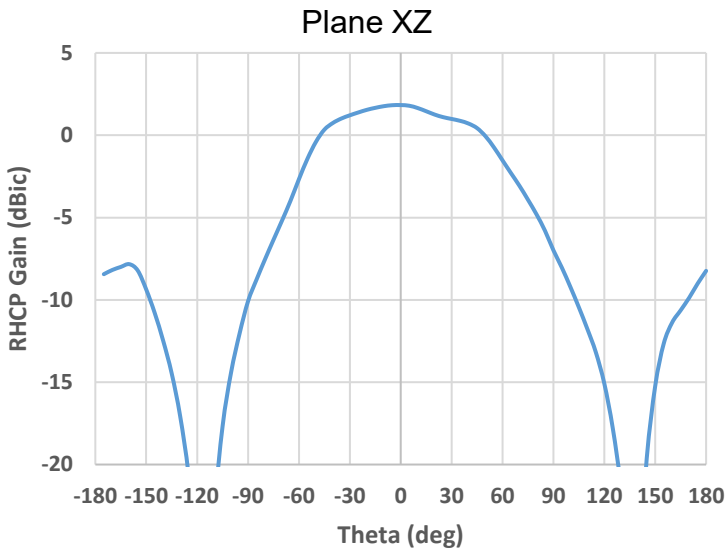

Dual-Feed GPS L1/L5 Stacked Patch Antenna Specifications.
KYOCERA AVX produces a wide variety of standard and custom antennas to meet user needs.

R.H.C.P Gain and Axial Ratio Data

Typical performance 9003379 measured over 70 x 70 mm EVB @1575 MHz

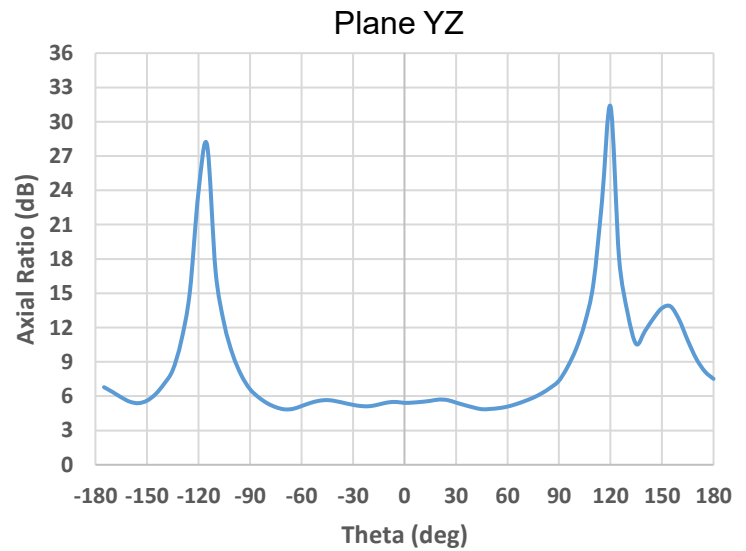
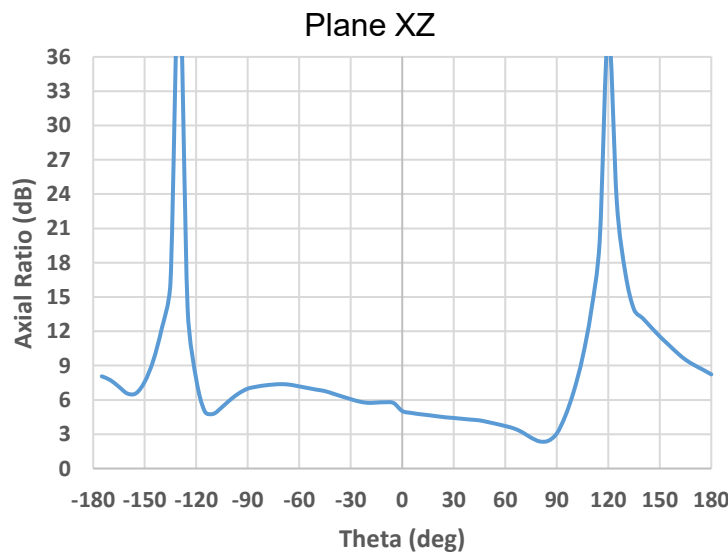
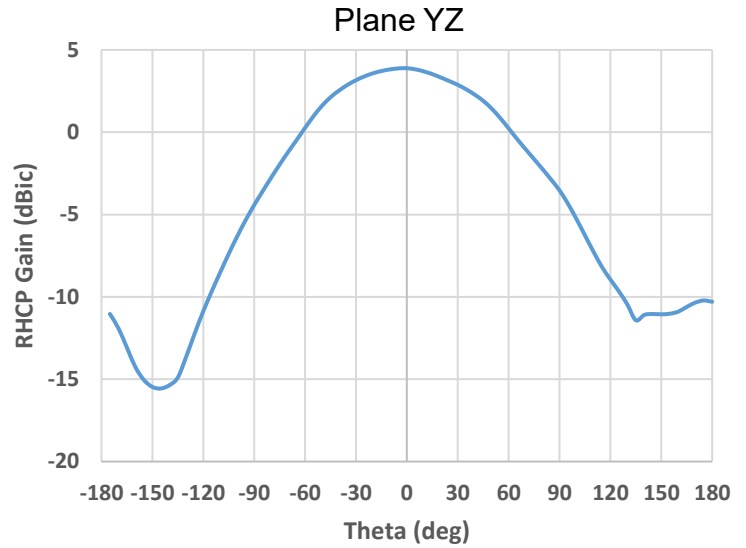
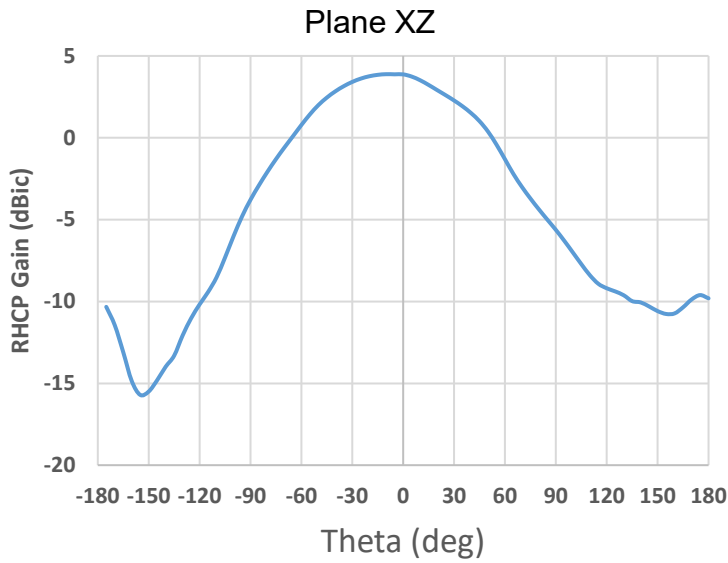

Dual-Feed GPS L1/L5 Stacked Patch Antenna Specifications.
 KYOCERA AVX produces a wide variety of standard and custom antennas to meet user needs.

Antenna Layout (9003379-01)

Typical Layout Dimensions (mm)
 PCB Thickness 0.8 mm

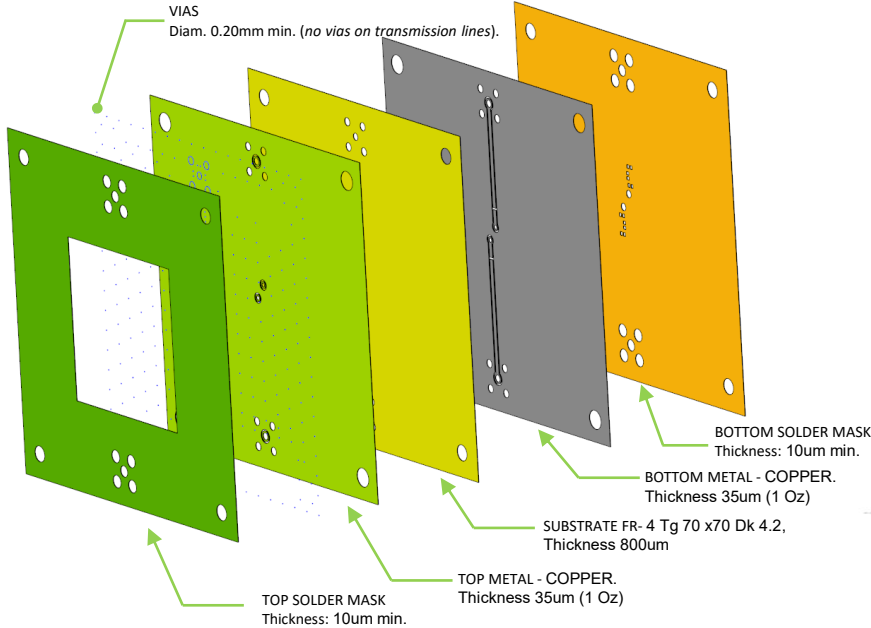

- Additional VIAS: Diam. 0.20 mm to be placed around antenna, (no vias on transmission lines).
- Via holes must be covered by solder mask

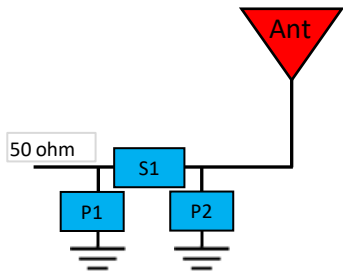
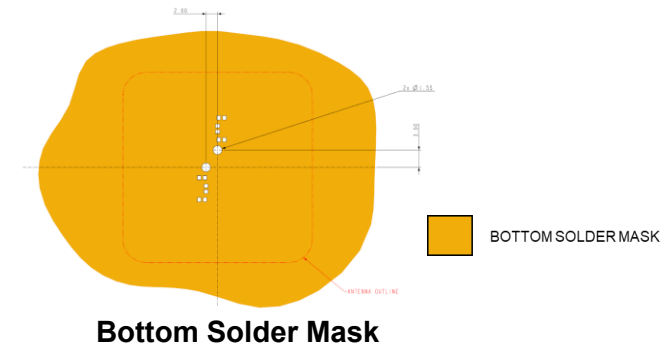
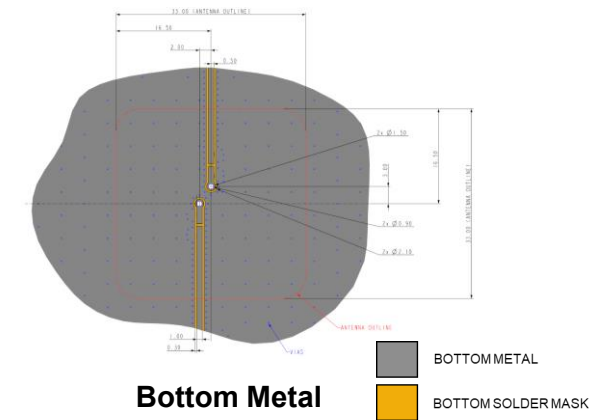
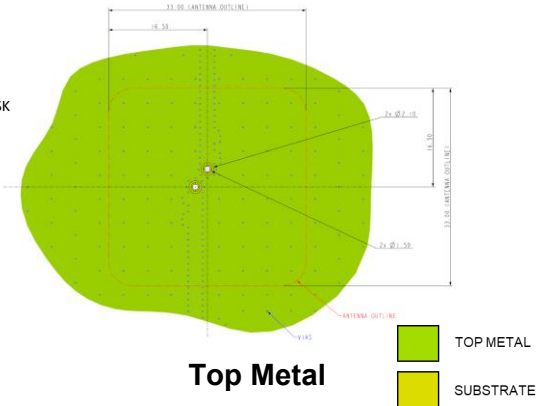
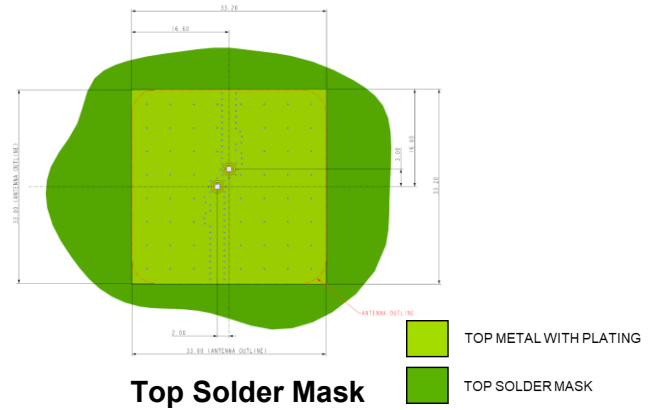

Matching Pi Network (L1)

Component	Value	Tolerance
P1	N/A	N/A
S1	0 ohms	0 ohms
P2	N/A	N/A

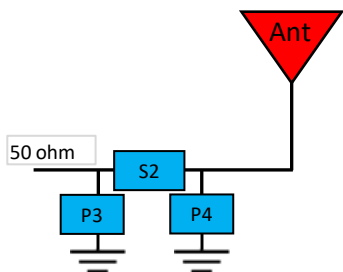

Matching Pi Network (L5)

Component	Value	Tolerance
P1	N/A	N/A
S1	0 ohms	0 ohms
P2	N/A	N/A

Dual-Feed GPS L1/L5 Stacked Patch Antenna Specifications.
 KYOCERA AVX produces a wide variety of standard and custom antennas to meet user needs.

Mechanical Specifications

Typical antenna dimensions in mm
 Two Couplers are added on the back of the EVB

Part Number	A	B	C
9003379	33 ± 0.40	33 ± 0.40	9.5 ± 0.6

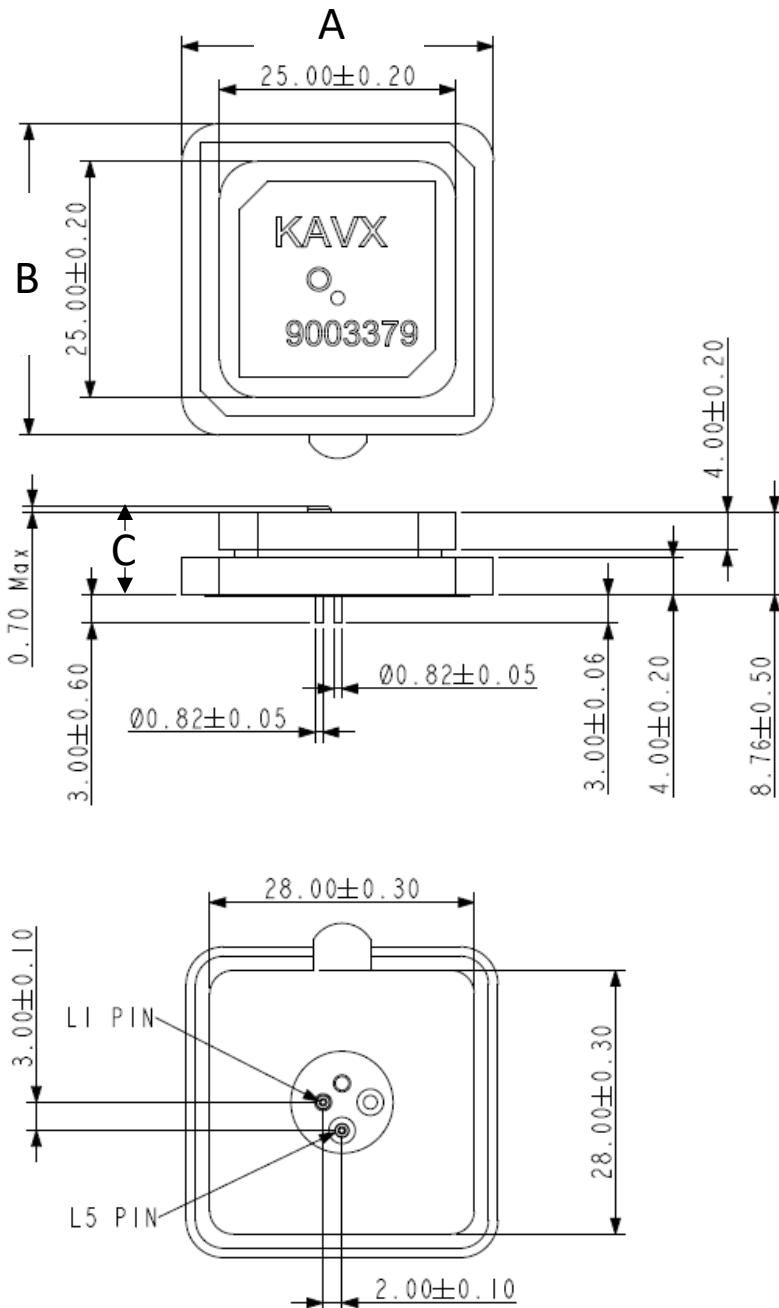

Dual-Feed GPS L1/L5 Stacked Patch Antenna Specifications.
 KYOCERA AVX produces a wide variety of standard and custom antennas to meet user needs.

Antenna Demo Board

Part Number	A (mm)	B (mm)
9003379-01	70.0	70.0

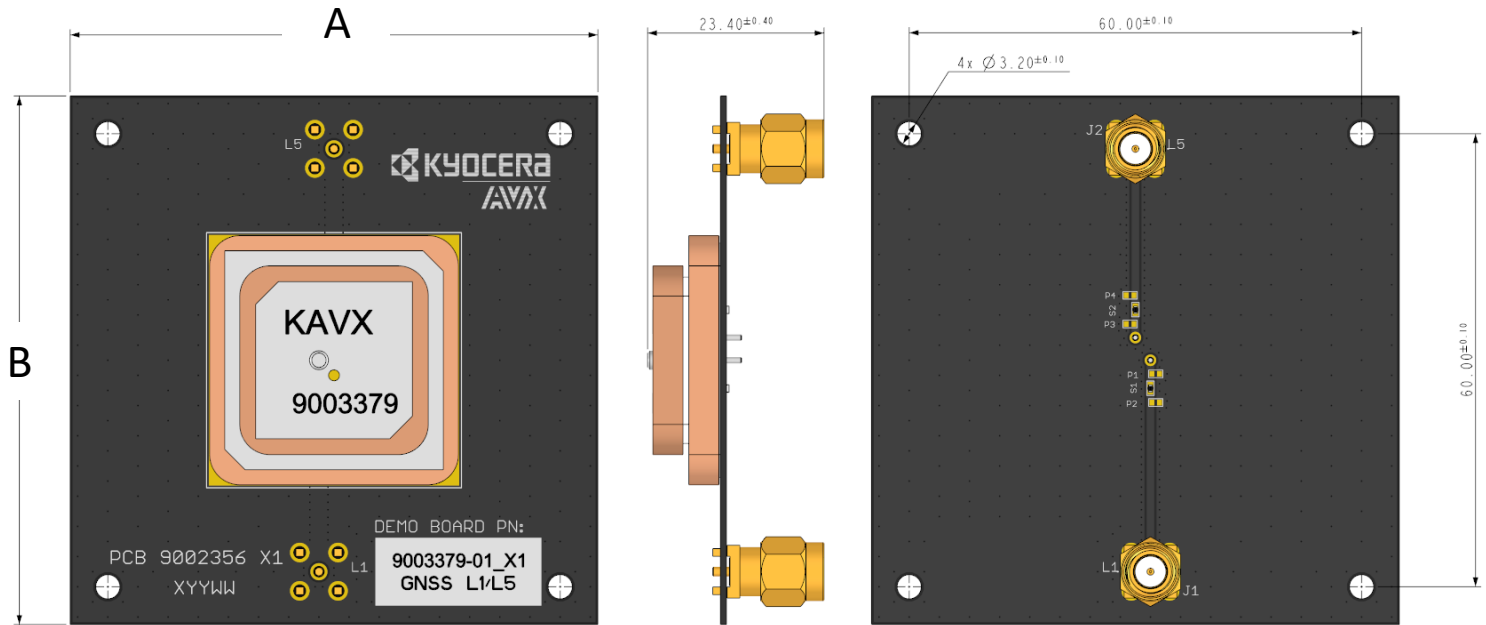

Dual-Feed GPS L1/L5 Stacked Patch Antenna Specifications.
KYOCERA AVX produces a wide variety of standard and custom antennas to meet user needs.

Additional Resources - 9003379

3D FIT File:

https://www.kyocera-avx.com/download/antennas/ME-FIT/9003379_ME_fit.zip

DXF File:

https://www.kyocera-avx.com/download/antennas/3D-DXF/9003379_3D-DXF.zip