

Oven Controlled Crystal Oscillator

36 x 27mm Low Noise OCXO – Family Data Sheet



FEATURES

- Thru Hole or Surface Mountable
- Superior Frequency Stability
- Ultra Low Phase Noise
- Low Acceleration Sensitivity
- Tolerant to Micro Vibrations
- Low Age Rates
- 36 x 27mm Package

KYOCERA AVX's ultra low phase noise OCXO product offering is a result of 90+ years of leading products within the Frequency Control Industry. Modern layout topologies enable KYOCERA AVX to engineer and manufacture robust designs for all applications.

HOW TO ORDER

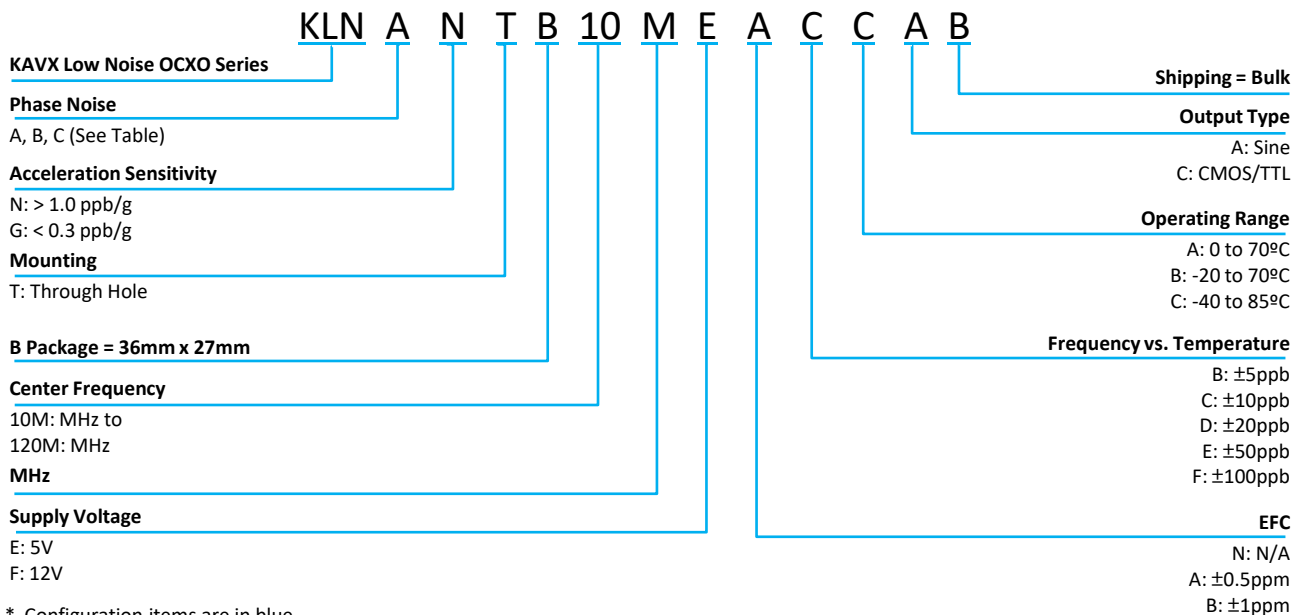

* Configuration items are in blue
 ** Not all combinations of options may be possible
 *** Other options may be available

APPLICATIONS

- Network Infrastructure
- Phase Locked Microwave Applications
- Low Noise Test and Measurement Systems
- GPS Precision Timing Devices
- Military High-Performance Devices
- Medical Devices
- Aerospace
- Industrial

BLOCK DIAGRAM

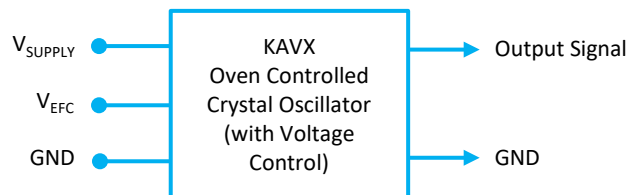

Note: If EFC Option "N" is used, connect V_{EFC} to GND



The Important Information/Disclaimer is incorporated in the catalog where these specifications came from or available online at www.kyocera-avx.com/disclaimer/ by reference and should be reviewed in full before placing any order

Oven Controlled Crystal Oscillator

36 x 27mm Low Noise OCXO – Family Data Sheet



PERFORMANCE SPECIFICATIONS

Parameter	Conditions	Values			Unit
		MIN	TYP	MAX	
Frequency Range		10		120	MHz
Initial Tolerance	10 MHz @ +25°C (Nominal)			±100	ppb
	100 MHz @ +25°C (Nominal)			±250	ppb
Warm Up Time	To initial tolerance			5	Min
Frequency Stability					
vs. Temperature	Options B - (Max-Min)/2		±5		ppb
	Options C - (Max-Min)/2		±10		ppb
	Options D - (Max-Min)/2		±20		ppb
	Options E - (Max-Min)/2		±50		ppb
	Options F - (Max-Min)/2		±100		ppb
vs. Load	± 5% Δ in Load		±2		ppb
vs. Supply Voltage	± 5% Δ in supply		±2		ppb
ADEV (Short Term Stability)	T = 1 second		5E-12		
Aging					
Per Day	10 MHz			±1.0	ppb
				±100	ppb
1 st Year	10 MHz			±100	ppb
				±500	ppb
Per Day	100 MHz			±5.0	ppb
				±500	ppb
1 st Year	100 MHz			±500	ppb
Supply Voltage (Vdd)	Option E	4.75	5	5.25	Vdc
	Option F	11.4	12	12.6	Vdc
Power Dissipation					
Start Up	@ +25°C (Nominal)			5.2	W
Steady State	@ +25°C (Nominal)		1.5		W
Electronic Frequency Control					
Voltage Range	Vdd = 5 Vdc	0	2.5	5	Vdc
	Vdd = 12 Vdc	0	5	10	Vdc
Frequency Range	Option N	0			ppm
	Option A	±0.5			ppm
	Option B	±1.0			ppm
Slope			positive		
Input Impedance			100		kΩ
Linearity			10		%

Note: Values typical of 10MHz units unless defined within



The Important Information/Disclaimer is incorporated in the catalog where these specifications came from or available online at www.kyocera-avx.com/disclaimer/ by reference and should be reviewed in full before placing any order

Oven Controlled Crystal Oscillator

36 x 27mm Low Noise OCXO – Family Data Sheet



PERFORMANCE SPECIFICATIONS

Parameter	Conditions	Values			Unit
		MIN	TYP	MAX	
Output Characteristics (CMOS/TTL)					
High Output Level	Logic "1"	90% Vdd			Vdc
Low Output Level	Logic "0"	10% Vdd			Vdc
Rise/Fall Time		5			nSec
Duty Cycle		45	50	55	%
Load		15			pF
Output Characteristics (Sinusoid)					
Output Level		10		16	dBm
Spurious		-80			dBc
Harmonics		-30			dBc
Load		47.5	50	52.5	Ω

Parameter	Conditions	Values			Unit
		A ^{1,2}	B ¹	C	
Phase Noise					
Phase Noise (10 MHz)	Tested at +25°C (Nominal)				
	10Hz	-130	-125	-120	dBc/Hz
	100Hz	-155	-152	-140	dBc/Hz
	1kHz	-166	-160	-145	dBc/Hz
	10kHz	-173	-170	-155	dBc/Hz
	100kHz	-175	-170	-155	dBc/Hz
Phase Noise (100 MHz)	Tested at +25°C (Nominal)				
	10Hz	-103	-100	-95	dBc/Hz
	100Hz	-133	-130	-125	dBc/Hz
	1kHz	-157	-155	-145	dBc/Hz
	10kHz	-172	-168	-160	dBc/Hz
	100kHz	-175	-172	-170	dBc/Hz

1. Specific Phase Noise performance is subject to Export Control restrictions from the U.S.
2. Please contact Kyocera AVX to analyze Phase Noise requirements that must be lower

Note: Values typical of 10MHz units



The Important Information/Disclaimer is incorporated in the catalog where these specifications came from or available online at www.kyocera-avx.com/disclaimer/ by reference and should be reviewed in full before placing any order

Oven Controlled Crystal Oscillator

36 x 27mm Low Noise OCXO – Family Data Sheet



ENVIRONMENTAL COMPLIANCE

Parameter	Conditions	Values			Unit
		MIIN	TYP	MAX	
Operating Temperature	Option A	0		+70	°C
	Option B	-20		+70	°C
	Option C	-40		+85	°C
Storage Temperature		-55		+100	°C
Seal	MIL-STD-202 Method 112 Test Condition D				
Shock	MIL-STD-202G Method 213 Test Condition C				
Random Vibration	MIL-STD-810G Method 514 Test Procedure I				
Sinusoidal Vibration	MIL-STD-202G Method 204 Test Condition A				
MTTF	Calculated using MIL-HDBK-217		153,300		Hours
Acceleration Sensitivity	10MHz output Vibration profile: 0.001G ² /Hz 10Hz to 2kHz		1.0		ppb/g
	"G" Option			0.3	ppb/g



The Important Information/Disclaimer is incorporated in the catalog where these specifications came from or available online at www.kyocera-avx.com/disclaimer/ by reference and should be reviewed in full before placing any order

Oven Controlled Crystal Oscillator

36 x 27mm Low Noise OCXO – Family Data Sheet



MECHANICAL SPECIFICATIONS – THROUGH HOLE

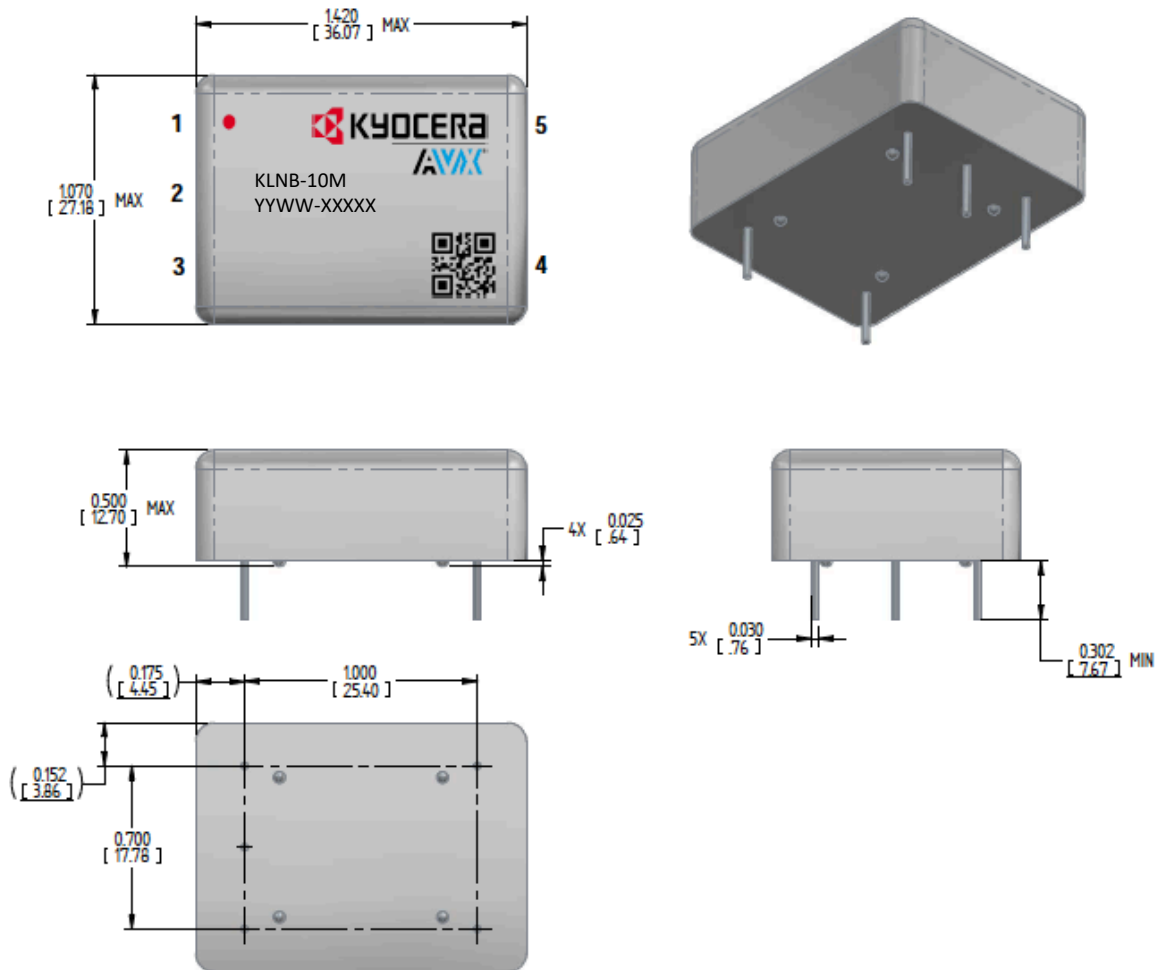

MARKING

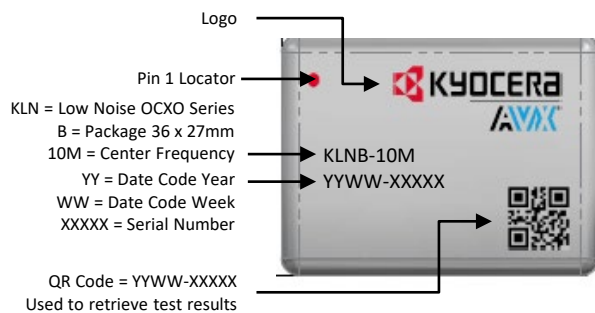

Tolerances (mm) .X = ± 0.5, .XX = ± 0.2 unless otherwise specified

PIN	FUNCTION
1	EFC / N.C.
2	N.C.
3	Supply Voltage
4	RF Output
5	Ground

Notes:

- Non-RoHS available upon request



The Important Information/Disclaimer is incorporated in the catalog where these specifications came from or available online at www.kyocera-avx.com/disclaimer/ by reference and should be reviewed in full before placing any order